

This application is used for automatic level adjustment for ambient noise.

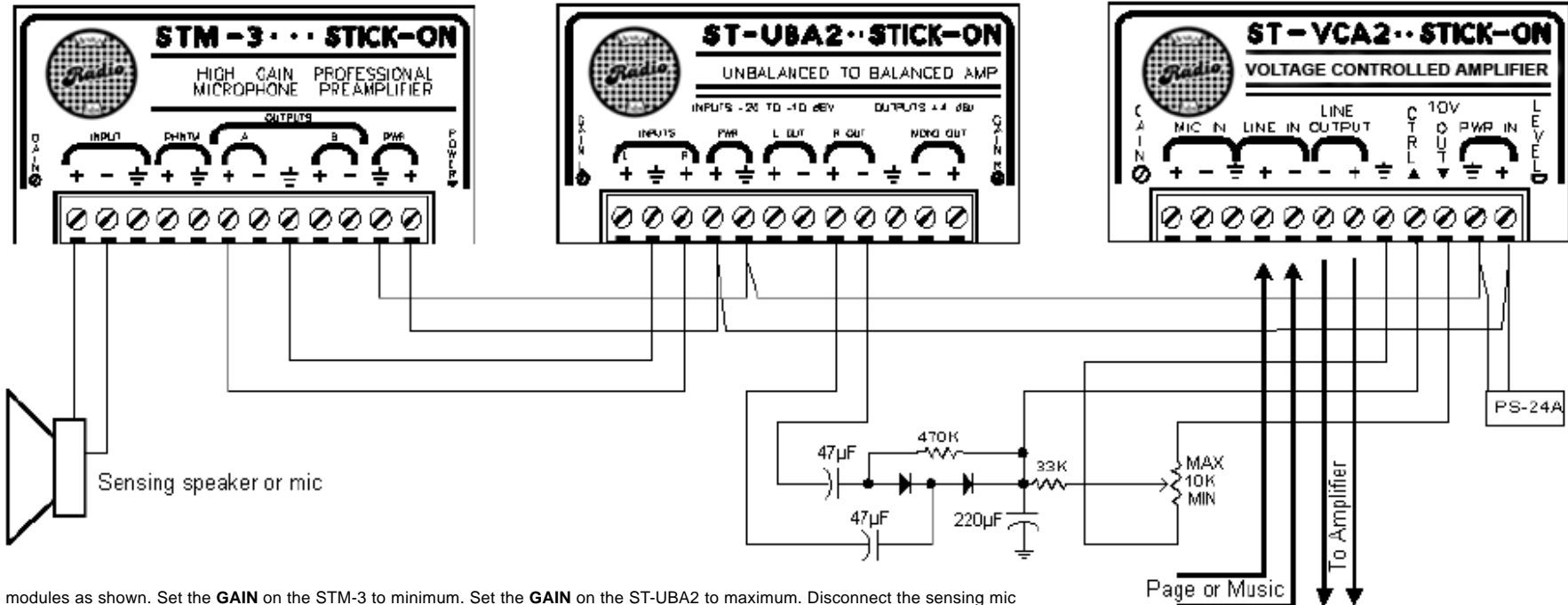

Setup:
Install the modules as shown. Set the **GAIN** on the STM-3 to minimum. Set the **GAIN** on the ST-UBA2 to maximum. Disconnect the sensing mic before beginning adjustment procedure. It is important to locate the sensing mic so it picks up ambient noise, but does not pick up sound from the system loudspeakers.

Adjustment:
1) Set the external 10 kΩ potentiometer to the MAX position, then apply power to the modules. There will be approximately 10Vdc Ground referenced at the **CTRL** terminal of the ST-VCA2.

note: Whenever the potentiometer is adjusted, the volume adjusts slowly. Allow the volume to settle when determining if an adjustment is correct.

2) With the normal audio source (music or paging) applied, set the GAIN potentiometer on the ST-VCA2 for correct input level as indicated on the Dual-LED meter in the ST-VCA2. Then set the zone audio power amplifier level to the loudest volume ever desired in the zone.

3) Adjust the external 10 kΩ potentiometer to produce the lowest audio level ever desired in the zone (allow settling time when making this adjustment).

4) Connect the sensing mic and simulate the ambient noise level for which it is desired to begin increasing the gain of the normal audio source. Adjust the STM-3 **GAIN** until the normal audio level increases proportionally (the system will be more sensitive to changes in ambient level as the STM-3 **GAIN** is increased).

5) Further increase the ambient room noise and verify that the location of the sensing mic does not pick up sound from the system speakers, thereby producing runaway expansion. If this occurs, decrease the STM-3's **GAIN** or relocate the sensing mic as required to prevent runaway expansion.

note: If the sensing mic is sufficiently close to the ambient noise source, the ST-UBA2 may not be required.

RDL PRODUCTS

1	ST-UBA2	Unbalanced to Balanced Amplifier	ST-UBA2	Linepegelverstärker von unsym. in sym.	ST-UBA2	Convertidor de Linea, No-Balanceado a Balanceado	ST-UBA2	Amplificateur Asymétrique/Symétrique
1	ST-VCA2	Voltage Controlled Amplifier	ST-VCA2	Spannungsgeregelter Verstärker	ST-VCA2	Amplificador Controlado por Voltaje	ST-VCA2	Amplificateur Contrôlé par Tension VCA
1	STM-3	High Gain Microphone Preamplifier	STM-3	Mikrofon-Vorverstärker	STM-3	Preamplificador de Micrófono	STM-3	Préamplificateur Micro