



**RDL**<sup>®</sup>  
Radio Design Labs

SPECIALISTS IN PRACTICAL PRECISION ENGINEERING™

## ACCESSORIES

### Model RLC-10R

### Remote Level Control Rotary Encoder

#### ANYWHERE YOU NEED...

- Rotary Encoder Remote Level Adjustment
- Direct 0 to 10 Vdc Output from a Remote Control
- Up/Down Pulse Output from a Remote Control
- 0 to 10 Vdc LED Display of Internal/External Voltage
- Optical Encoding for Long Life
- Noise-Free Performance
- Professional High Quality Appearance
- RDL *ULTRASTYLE*™ Design

#### **You Need The RLC-10R!**

The RLC-10R is part of the group of remote control accessories from Radio Design Labs. The rugged high quality construction and professional styling make the RLC-10R the optimum choice for level control in critical high quality installations.

**APPLICATION:** The RLC-10R is the ideal choice for 0 to 10 Vdc or pulsed control from a remote location. Control is based on optical encoder technology to produce long-term trouble-free operation.

Two output modes are simultaneously available. The 0 to 10 Vdc output operates continuously. Up and down pulses from the optical encoder are also provided on the rear barrier block. The 0 to 10 V output is used to control RDL VCA products, and may be connected to a wide range of other industry 0 to 10 Vdc controlled equipment. This mode is used for single point control. If multiple control points are desired, the pulse outputs may be connected to RDL RU-VCA products and various other industry products. A rear-panel jumper sets the PULSE outputs to either produce +15 Vdc pulses or momentary open collector pulses.

Control is incremented up or down when the large front-panel knob is rotated. Acceleration is provided so the rate of change is faster when the knob is rotated more rapidly, yielding a responsive feel.

The LED ring display encircling the control knob operates as a virtual pointer. The input to this display is a 0 to 10 Vdc signal. A strap on the module rear barrier block determines if the display operates from the internally generated control voltage or from an external control voltage. Typically, if the 0 to 10 Vdc control voltage from the RLC-10R is being used to control a VCA, the internal control voltage is also used for the display. If the RLC-10R pulse outputs are used with RDL RU-VCA modules, the 0 to 10 Vdc **EQRAMP** from the VCA module is fed back to the RLC-10R. Therefore, multiple RLC-10R modules may be connected together with all modules providing the same level indication.

In the event of power loss, internal non-volatile memory stores the last level value. When power returns, the 0 to 10 V output will return to the operating level present when power was lost.

Wherever the highest quality, durability, performance and appearance are required in remote level control, the RLC-10R is the ideal choice. Use the RLC-10R individually, or combine it with other RDL products as part of a complete audio/video system.



Additional *ULTRASTYLE* design options shown at [www.rdlnet.com](http://www.rdlnet.com)

# ACCESSORIES

## Model RLC-10R

### Remote Level Control Rotary Encoder

## Installation/Operation



EN55103-1 E1-E5; EN55103-2 E1-E4  
Typical Performance reflects product at publication time exclusive of EMC data, if any, supplied with product. Specifications are subject to change without notice.

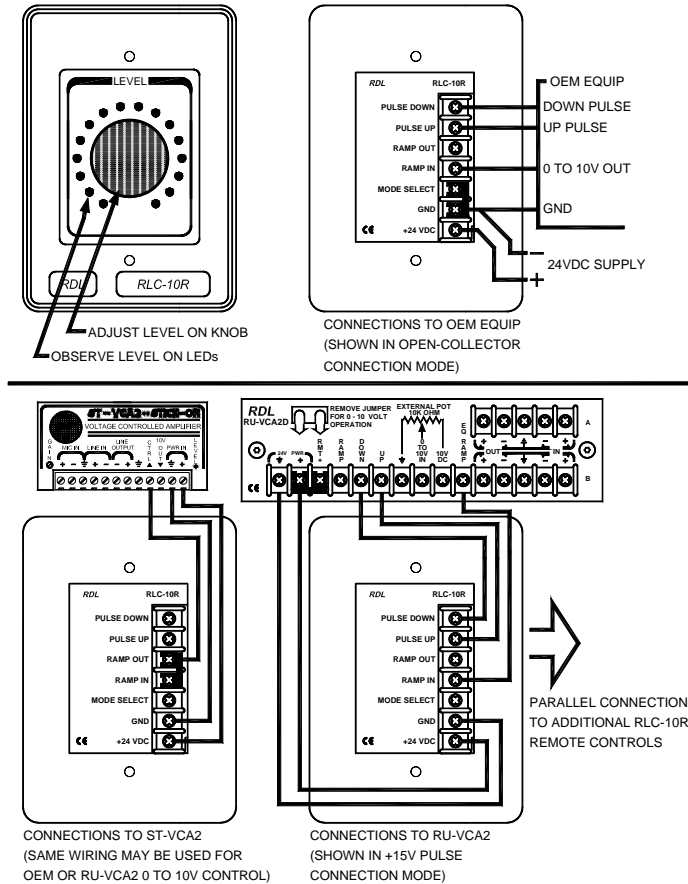

NOTE: Wiring between VCA and RLC-10R must be electrically shielded, either by installation in a metal conduit or using shielded cable. When shielded cable is used without conduit (or in nonmetallic conduit), the shield should be connected to the RLC-10R mounting enclosure.

### TYPICAL PERFORMANCE

Ramp output:	0 to 10 Vdc
Pulse outputs (2):	<b>PULSE UP, PULSE DOWN</b> (programmable open collector, or +15 V pulse)
	20 mA (open collector)
Pulse output current:	200 kΩ
Display RAMP IN input resistance:	0 to 10 Vdc
Display input voltage:	5 (slow rotation, no acceleration)
Rotations, approximate min-to-max:	3 (medium rotation, with acceleration)
	1 (fast rotation counterclockwise, anti-feedback mode)
Power Requirement:	24 Vdc @ 50 mA, Ground-referenced
Overall Dimensions:	Height: 4.9 in. 12.44 cm
	Width: 3.4 in. 8.63 cm
	Depth: 1.6 in. 4.06 cm

NOTE: This equipment has been tested and found to comply with the limits for a Class B digital device, pursuant to part 15 of the FCC Rule. These limits are designed to provide reasonable protection against harmful interference in a residential installation. The equipment generates, uses and can radiate radio frequency energy and, if not installed and used in accordance with the instructions, may cause harmful interference to radio communications. However, there is no guarantee that interference will not occur in a particular installation. If this equipment does cause harmful interference to radio or television reception, which can be determined by turning the equipment off and on, the user is encouraged to try to correct the interference by one or more of the following measures:

- Reorient or relocate the receiving antenna
- Increase the separation between the equipment and receiver
- Connect the equipment into an outlet on a circuit different from that which the receiver is connected.
- Consult the dealer or an experienced radio/TV technician for help.