



RDL[®]
Radio Design Labs

SPECIALISTS IN PRACTICAL PRECISION ENGINEERING™

RACK-UP[®] SERIES

Models RU-VCA2 & RU-VCA2D

Digitally Controlled Attenuator

ANYWHERE YOU NEED...

- Remote Controllable Audio Levels
- Wide Attenuation Range in 1 dB Steps
- Attenuation to -96 dB, then OFF
- Multiple Control Locations Possible
- Precise Level Tracking (Stereo)
- Line-Level Balanced/Unbalanced
- Adjustable Ramp Up/Down Times
- Control by Pushbutton, external 0 -10 Vdc or 10 kΩ Pot
- Return to PRESET Function (pushbutton operation)
- Mono (RU-VCA2) or Stereo (RU-VCA2D) Attenuation



You Need The RU-VCA2!

APPLICATION: The RU-VCA2 is the ideal choice in many installations where either local and/or remote audio level control is desired. Single or multiple remote control locations are possible using optional RDL RLC2 Remote Level Controls; single location remote control is possible using an RLC10K.

The RU-VCA2 rear-panel input(s) and output(s) may each be wired balanced or unbalanced. Bridging inputs allow either high or low impedance sources. The output is line-level, low-impedance balanced.

The RU-VCA2 powers up in one of two operating modes set by a rear panel jumper. In the normal mode, audio level is controlled by momentary pushbuttons. Remote pushbutton terminals and front-panel pushbuttons are provided for *ramp up* and *ramp down* operation. If either button is held in, the audio will ramp automatically. If a button is pulsed (< ½ second), the audio will increment one step. The time of both the *up* and *down* ramps is individually adjustable on the front panel. Pushing remote **UP** and **DOWN** buttons simultaneously immediately returns the audio to a preset level. The *preset* level is set on the RU-VCA2 front panel by holding the **GO TO PRESET** button in while adjusting the **SET LEVEL** trimming potentiometer for the desired level. Multiple remote control locations are possible in the normal mode. In the alternate mode the preset function is disabled and the audio level is controlled by a remote 10 kΩ linear taper pot or by 0 to 10 Vdc. A single location is possible using a remote 10 kΩ pot. In both modes, two separate 0 to 10 Vdc outputs are provided. The **RAMP** output drives the level display on an RDL RLC2 Remote Control; the **EQ RAMP** output is used to control an RDL Loudness Equalizer (see ST-LEQ1). A front-panel, variable-intensity LED indicates the relative audio level. Two additional LEDs indicate when the RU-VCA2 audio level is off or fully on (unity gain).

Audio levels are controlled in the RU-VCA2 using digital attenuators for optimum reliability, precise tracking and long-term noise-free performance. Use the RU-VCA2 individually, or combine it with other RDL RACK-UP, STICK-ON[®] or FLAT-PAK[™] products as part of a complete audio/video system.



RDL[®]
Radio Design Labs

SPECIALISTS IN PRACTICAL PRECISION ENGINEERING™



RACK-UP® SERIES

Models RU-VCA2 & RU-VCA2D Digitally Controlled Attenuator

Installation/Operation



EN55103-1 E1-E5; EN55103-2 E1-E4
Typical Performance reflects product at publication time exclusive of EMC data, if any, supplied with product. Specifications are subject to change without notice.

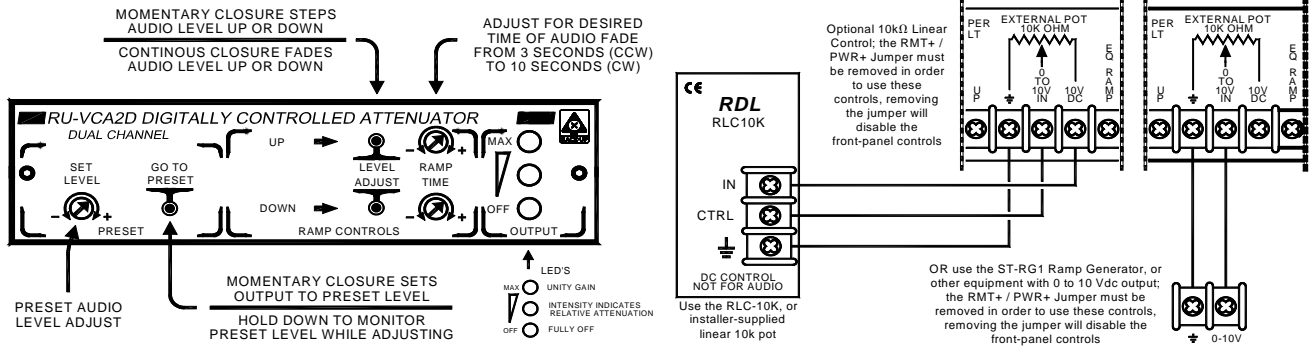
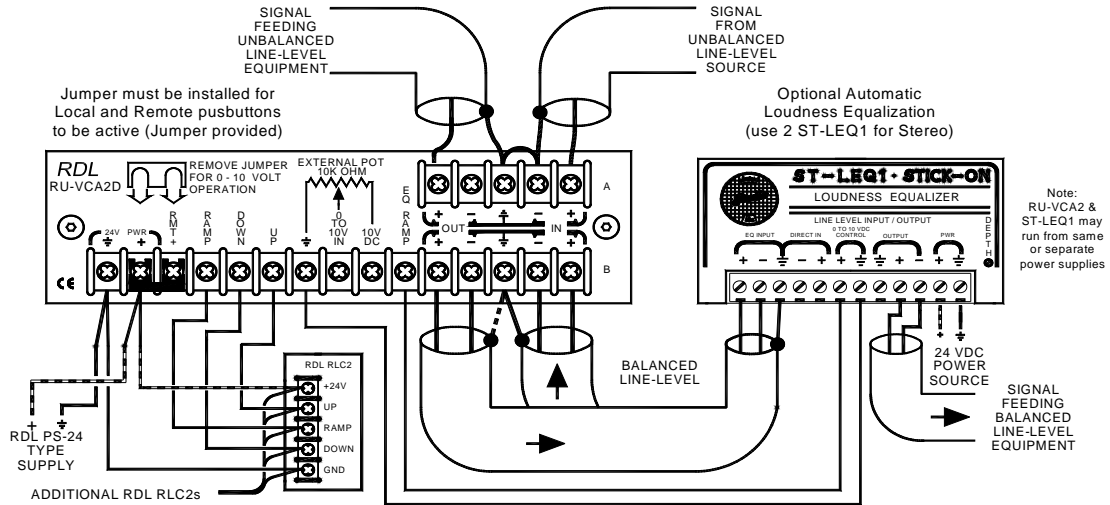

TYPICAL PERFORMANCE

Input(s): 10 kΩ Balanced bridging, or Unbalanced, line level
 Frequency Response: 10 Hz to 30 kHz (+/- 0.25 dB into bridging input)
 THD+N: < 0.002% (20 Hz to 20 kHz)
 Gain: Adjustable from unity to -96 dB, then OFF (bottom step)
 Steps: 1dB (Unity to -50dB), 1.5dB (-50 to -60dB), 2.5dB (-60 to -68dB), -72dB, -77dB, -84dB, -96dB, OFF > 110 dB (1 kHz), > 85 dB (20 Hz - 20kHz)
 Off Attenuation: > 20 dB (above +4 dBu)
 Headroom: < -95 dB (referred to +4 dBu with level set fully ON)
 Residual Noise: < -100 dB (referred to +4 dBu with level set fully OFF) < 0.0001 %
 Intermodulation Distortion: 65 dB (50 to 120 Hz)
 CMRR: < -90 dB (20 Hz to 20 kHz; Right into Left, or Left into Right)
 Crosstalk (RU-VCA2D): 0.5 second delay; then: 3 seconds to 10 seconds (UP and DOWN times individually adjustable on front panel)
 Ramp Times: Front-panel LEDs indicating; relative audio level (variable intensity yellow), fully ON condition (green), fully OFF condition (red)
 Indicators (3): Balanced @ 150 Ω to drive hi or low impedance, balanced or unbalanced line
 Audio Output(s): 0 to 10 Vdc, (Ground-referenced) Note: Not intended to drive additional VCA 0-10V inputs
 Ramp Output: 0 to 10 Vdc, (Ground-referenced) Note: dc taper intended only to drive RDL Loudness EQ (ST-LEQ1)
 EQ Ramp Output: 24 Vdc @ 140 mA, Ground-referenced
 Power Requirement:

NOTE: This equipment has been tested and found to comply with the limits for a Class B digital device, pursuant to part 15 of the FCC Rule. These limits are designed to provide reasonable protection against harmful interference in a residential installation. The equipment generates, uses and can radiate radio frequency energy and, if not installed and used in accordance with the instructions, may cause harmful interference to radio communications. However, there is no guarantee that interference will not occur in a particular installation. If this equipment does cause harmful interference to radio or television reception, which can be determined by turning the equipment off on, the user is encouraged to try to correct the interference by one or more of the following measures:

- Reorient or relocate the receiving antenna
- Increase the separation between the equipment and receiver
- Connect the equipment into an outlet on a circuit different from that which the receiver is connected.
- Consult the dealer or an experienced radio/TV technician for help.

Dimensions:	Height:	1.7 in.	4.3 cm
	Length:	5.8 in.	15.0 cm
	Depth:	2.0 in.	5.1 cm
		2.5 in.	6.4 cm
			(case only)
			(including barrier block)

Radio Design Labs Technical Support Centers
 U.S.A. (800) 933-1780, (928) 778-3554; Fax: (928) 778-3506
 Europe [NH Amsterdam] (+31) 20-6238 983; Fax: (+31) 20-6225-287